

# **SINGER**

## **410W101**

Form 2926w

(447)

Printed in U. S. A.

# LIST OF PARTS



MACHINE No. 410w101

---

THE SINGER MANUFACTURING COMPANY

## INDEX

---

|                               | Page |
|-------------------------------|------|
| Accessories .....             | 12   |
| Knee Lifter .....             | 12   |
| Machine No.410w101 .....      | 5    |
| Numerical List of Parts ..... | 13   |

From the library of: Diamond Needle Corp

Copyright, U. S. A., 1941 and 1947  
by The Singer Manufacturing Co.  
All Rights Reserved for all Countries

# INSTRUCTIONS FOR ORDERING

## LIST OF PARTS COMPLETE

FOR

In ordering from this list, use ONLY the PART number in the FIRST column.

The number stamped on a Sewing Machine Part is the number of the Single Part only, except when the part includes Set Screws, Clamping Screws, Studs and Rollers Spun on, Small Wires riveted, or Parts soldered together, etc., which it is necessary to furnish in combination.

Every combination of parts sent out has its specific number which, although not stamped on Parts (except in above case), must be used when ordering the combination.

Each number always indicates the SAME PART in whatever list it appears, or for whatever Machine.

The letters after some of the numbers indicate the style of finish only, as follows:

- A. Hardened, Polished, Nickel Plated and Buffed.
- B. Polished, Nickel Plated and Buffed.
- C. Hardened only.
- D. Polished only.
- E. Soft, not polished.
- F. Hardened and Polished.
- H. Blued.
- J. Nickel Plated only.
- R. Merlized.
- X. Black Oxide.
- XC. Hardened and Black Oxide.
- Y. Black Nickel only.

These letters MUST BE USED when they appear in the list and AFTER the number, as in the list.

In this series:

200001 to 201500 and 350001 to 351500 are Screw Numbers.  
 201501 to 201800 and 351501 to 351800 are Nut Numbers.  
 201801 to 202000 and 351801 to 352000 are Roller Numbers.  
 202001 to 350000 are Numbers of Machine Parts.

The figures in the second column refer only to the plate in which the illustration of the part is shown and are NOT TO BE USED in ordering.

Two or more numbers over a cut indicate that the difference between such parts is not visible in an illustration.

Parts marked with an asterisk (\*) are furnished when repairs are made at the factory.

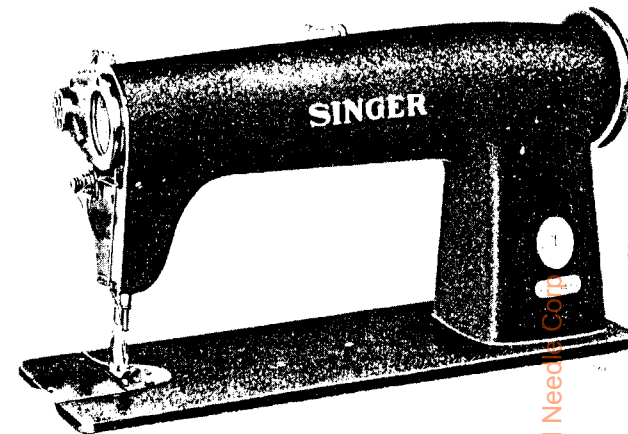

## MACHINE No. 410w101

DOUBLE ROTARY DISC TAKE-UP

HIGH SPEED, LONG ARM, DROP FEED

SINGLE NEEDLE. SINGLE THREAD CHAIN STITCH

MAXIMUM STITCH 2 TO THE INCH

For Edge Basting On Heavy Overcoats and Similar Work

| No.     | Plate | Name                                                      |
|---------|-------|-----------------------------------------------------------|
| *270251 | ----- | Arm                                                       |
| 270002  | 18292 | " Cover Plate (back)                                      |
| 200041X | 18292 | " " " Screw (2)                                           |
| 204235  | 18292 | " Position Pin (2)                                        |
| 200004E | 18292 | " Screw (3)                                               |
| 202005  | 18292 | " " Washer (3)                                            |
| *270252 | 18293 | " Shaft                                                   |
| 270287  | 18293 | Arm Shaft 270252 with 200333C, 200362C, 270005 and 270268 |
| 270004  | 18293 | Arm Shaft Ball Bearing (back)                             |
| 270005  | 18293 | " " " " (front)                                           |
| 270167  | 18293 | " " Connection Belt                                       |

From the library of: Diamond Needle Co.

## PARTS FOR MACHINE No. 410w101

| No.                                                                                            | Plate | Name                                                                                                      |
|------------------------------------------------------------------------------------------------|-------|-----------------------------------------------------------------------------------------------------------|
| 270168                                                                                         | 18293 | Arm Shaft Connection Belt Pulley and Rotary Take-up Driving Pulley with 200363C, 350492C and three 214206 |
| 350492C                                                                                        | 18293 | Arm Shaft Connection Belt Pulley Position Screw                                                           |
| 200363C                                                                                        | 18293 | Arm Shaft Connection Belt Pulley Set Screw                                                                |
| 214206                                                                                         | 18293 | Arm Shaft Connection Belt Pulley Spring Flange                                                            |
| 270104                                                                                         | 18293 | Balance Wheel (belt groove 1-13/16 in. diam.) with two 200354AL                                           |
| Note: Balance Wheel 270171 is furnished with this machine unless otherwise specified on order. |       |                                                                                                           |
| 270105                                                                                         | 18293 | Balance Wheel 270104 with 270004, 270123 and two 350503H                                                  |
| 270170                                                                                         | 18293 | Balance Wheel "V" belt groove (outside diam. of belt groove 2.9 in.) with 201346AL and 350107AL           |
| 270171                                                                                         | 18293 | Balance Wheel 270170 with 270004                                                                          |
| 270123                                                                                         | 18293 | " " Cap                                                                                                   |
| 350503H                                                                                        | 18293 | " " " Screw                                                                                               |
| 350107AL                                                                                       | 18293 | " " Position Screw                                                                                        |
| 200354AL                                                                                       | 18293 | " " Set Screw                                                                                             |
| 201346AL                                                                                       | 18293 | " " " "                                                                                                   |
| *271051                                                                                        | ----- | Bed                                                                                                       |
| 20936                                                                                          | 18292 | " Slide                                                                                                   |
| 20937                                                                                          | 18292 | " " 20936 with 5947 and two 725J                                                                          |
| 5947                                                                                           | 18292 | " " Spring                                                                                                |
| 725J                                                                                           | 18292 | " " " Screw                                                                                               |
| 270308                                                                                         | 18294 | Face Plate                                                                                                |
| 350503H                                                                                        | 18294 | " " Screw (4)                                                                                             |
| 271052                                                                                         | 18295 | Feed Bar                                                                                                  |
| 270012                                                                                         | 18295 | " " Center (2)                                                                                            |
| 200394C                                                                                        | 18295 | " " " Set Screw                                                                                           |
| 15170                                                                                          | 18295 | " " Slide Block                                                                                           |
| 226J                                                                                           | 18295 | " " " " Cap Screw                                                                                         |
| 12424                                                                                          | 18295 | " " " " " Washer                                                                                          |
| 51372C                                                                                         | 18295 | " " " " " Screw Stud                                                                                      |
| 1519J                                                                                          | 18295 | " " " " " " Nut                                                                                           |
| 20978                                                                                          | 18295 | Feed Bar Slide Block complete, Nos. 226J, 12424, 15170 and 51372C                                         |
| 20993                                                                                          | 18296 | Feed Dog                                                                                                  |
| 211E                                                                                           | 18296 | " " Screw (2)                                                                                             |
| 271053                                                                                         | 18295 | " Driving Connection                                                                                      |
| 271054                                                                                         | 18295 | " " " 271053 with 271055                                                                                  |
| 270015                                                                                         | 18295 | Feed Driving Connection Crank with 200040E                                                                |
| 200040E                                                                                        | 18295 | Feed Driving Connection Crank Pinch Screw                                                                 |
| 200545C                                                                                        | 18295 | Feed Driving Connection Hinge Screw                                                                       |
| 201522E                                                                                        | 18295 | " " " " " Nut                                                                                             |
| 271055                                                                                         | 18295 | " " " Needle Bearing                                                                                      |
| 271056                                                                                         | 18297 | " " Eccentric                                                                                             |

## PARTS FOR MACHINE No. 410w101

| No.     | Plate | Name                                                                    |
|---------|-------|-------------------------------------------------------------------------|
| 271057  | 18297 | Feed Driving Eccentric Adjusting Disc                                   |
| 270137  | 18297 | Feed Driving Eccentric Adjusting Disc Spring                            |
| 271002  | 18297 | Feed Driving Eccentric Adjusting Disc Spring Collar with 201220C        |
| 201220C | 18297 | Feed Driving Eccentric Adjusting Disc Spring Collar Position Screw      |
| 200369C | 18297 | Feed Driving Eccentric Friction Adjusting Screw                         |
| 350101C | 18297 | Feed Driving Eccentric Friction Adjusting Screw Set Screw               |
| 201222C | 18297 | Feed Driving Eccentric Position Screw                                   |
| 271058  | 18297 | Feed Driving Flange with 200333C, 200346C, two each 200369C and 350101C |
| 200333C | 18297 | Feed Driving Flange Position Screw                                      |
| 200346C | 18297 | " " " Set Screw                                                         |
| 270021  | 18295 | " " Rock Shaft with two 200394C                                         |
| 270022  | 18295 | " " " " Center (2)                                                      |
| 350277C | 18295 | " " " " " Set Screw (2)                                                 |
| 270013  | 18295 | Feed Lifting Connection                                                 |
| 270014  | 18295 | " " " 270013 with 270016                                                |
| 270015  | 18295 | Feed Lifting Connection Crank with 200040E                              |
| 200040E | 18295 | Feed Lifting Connection Crank Pinch Screw                               |
| 200545C | 18295 | Feed Lifting Connection Hinge Screw                                     |
| 201522E | 18295 | " " " " " " Nut                                                         |
| 270016  | 18295 | Feed Lifting Connection Needle Bearing                                  |
| 271060  | 18297 | " " Eccentric with 200382C and 201220C                                  |
| 201220C | 18297 | Feed Lifting Eccentric Position Screw                                   |
| 200382C | 18297 | " " " Set Screw                                                         |
| 271061  | 18295 | " " Rock Shaft with 1519J and 20978                                     |
| 270022  | 18295 | Feed Lifting Rock Shaft Center (2)                                      |
| 350277C | 18295 | " " " " " Set Screw (2)                                                 |
| 270140  | 18297 | Feed Regulating Stud                                                    |
| 270026  | 18297 | " " " Spring                                                            |
| 240245  | 18297 | " " " Retaining Spring                                                  |
| 270256  | 18298 | Knee Lifter Lifting Link                                                |
| 270285  | 18292 | " " " " Connection                                                      |
| 200363C | 18292 | " " " " " Set Screw                                                     |

From the library of: Alan and Neale Barry

| No.     | Plate | Name                                                                                   |
|---------|-------|----------------------------------------------------------------------------------------|
| 200293C | 18298 | Knee Lifter Lifting Link Hinge Screw                                                   |
| 270094  | 18292 | " " " Rod                                                                              |
| 270048  | 18292 | " " " " Connection                                                                     |
| 200434C | 18292 | " " " " " Set Screw                                                                    |
| 270257  | 18292 | " " Rock Shaft with 200363C<br>and 200434C                                             |
| 271003  | 18297 | Looper                                                                                 |
| 270276  | 18297 | " Driving Shaft                                                                        |
| 270032  | 18297 | " " " Ball Bearing                                                                     |
| 271062  | 18297 | " " " Bushing with 222598                                                              |
| 222598  | 18297 | " " " " Oil Packing<br>(wick)                                                          |
| 200362C | 18297 | Looper Driving Shaft Bushing Set Screw                                                 |
| 270169  | 18297 | " " " Connection Belt<br>Pulley with 214206 and two 200070C                            |
| 200070C | 18297 | Looper Driving Shaft Connection Belt<br>Pulley Set Screw                               |
| 214206  | 18297 | Looper Driving Shaft Connection Belt<br>Pulley Spring Flange                           |
| 271004  | 18297 | Looper Driving Shaft Gear with 200382C,<br>201220C and 271006                          |
| 201220C | 18297 | Looper Driving Shaft Gear Position<br>Screw                                            |
| 200382C | 18297 | Looper Driving Shaft Gear Set Screw                                                    |
| 271005  | 18297 | " " " Oil Lead Wire                                                                    |
| 270038  | 18292 | " " " " Reservoir<br>Cover                                                             |
| 270039  | 18292 | Looper Driving Shaft Oil Reservoir<br>Cover Gasket                                     |
| 200041X | 18292 | Looper Driving Shaft Oil Reservoir<br>Cover Screw (6)                                  |
| 270155  | 18297 | Looper Driving Shaft Oil Reservoir<br>Oil Gauge                                        |
| *271006 | ----- | Looper Driving Shaft Oil Slinger                                                       |
| 271007  | 18297 | " Idler Shaft                                                                          |
| 271008  | 18297 | " " " Collar with two<br>50150AL                                                       |
| 50150AL | 18297 | Looper Idler Shaft Collar Set Screw                                                    |
| 271009  | 18297 | " " " Needle Bearing                                                                   |
| 200F    | 18297 | " Set Screw                                                                            |
| 271010  | 18297 | " Shaft                                                                                |
| 271044  | 18297 | " " Bushing                                                                            |
| 271045  | 18297 | " " " 271044 with 271007,<br>271008,271010,271013,271046,two<br>each 271009 and 270653 |
| 200917C | 18297 | Looper Shaft Bushing Position Screw                                                    |
| 271013  | 18297 | " " Collar with 200F and 462AL                                                         |
| 462AL   | 18297 | " " " Set Screw                                                                        |
| 271046  | 18297 | " " Friction Plate                                                                     |
| 270653  | 18297 | " " Needle Bearing                                                                     |
| 271066  | 18298 | Needle Bar                                                                             |
| 271063  | 18298 | " " 271066 with 51229D,127245<br>and 127246                                            |

| No.      | Plate | Name                                                   |
|----------|-------|--------------------------------------------------------|
| 270260   | 18298 | Needle Bar Bushing (lower)                             |
| 270261   | 18298 | " " " (upper)                                          |
| 350489AL | 18298 | " " " " Set Screw                                      |
| 270262   | 18298 | " " Connecting Link                                    |
| 270263   | 18298 | " " " " 270262<br>with 270266                          |
| 270264   | 18298 | Needle Bar Connecting Link Guide Block                 |
| 200054E  | 18298 | " " " " " " "<br>Screw (2)                             |
| 270286   | 18298 | Needle Bar Connecting Link Hinge Stud<br>with 210983   |
| 200374C  | 18293 | Needle Bar Connecting Link Hinge Stud<br>Set Screw     |
| 270266   | 18298 | Needle Bar Connecting Link Needle<br>Bearing           |
| 270267   | 18298 | Needle Bar Connecting Link Thrust<br>Washer            |
| 270057   | 18298 | Needle Bar Connecting Stud with<br>200086C and 202330  |
| 202330   | 18298 | Needle Bar Connecting Stud Oil Packing<br>(wick)       |
| 200086C  | 18298 | Needle Bar Connecting Stud Pinch Screw                 |
| *270268  | 18293 | " " Crank with two 200374C                             |
| 200333C  | 18293 | " " " Position Screw                                   |
| 200362C  | 18293 | " " " " " Check<br>Screw                               |
| 270058   | 18298 | Needle Bar Oiling Felt                                 |
| 127245   | 18298 | " " Thread Guard                                       |
| 51229D   | 18298 | " " " " Screw                                          |
| 127246   | 18298 | " Clamp with 140119F                                   |
| 140119F  | 18298 | " " Screw                                              |
| 271065   | 18298 | Presser Bar with 176J                                  |
| 270114   | 18298 | " " Bushing                                            |
| 270282   | 18298 | " " Lifter                                             |
| 350442C  | 18298 | " " " Hinge Screw                                      |
| 270062   | 18298 | " " Lifting Releasing Lever<br>Bracket                 |
| 270095   | 18298 | Presser Bar Lifting Releasing Lever<br>Bracket Spring  |
| 270063   | 18298 | Presser Bar Position Guide with<br>200196E and 350411C |
| 350411C  | 18298 | Presser Bar Position Guide Pinch Screw                 |
| 270271   | 18292 | " " Spring                                             |
| 350435C  | 18292 | " " " Screw (pressure<br>regulating)                   |
| 350499XC | 18292 | Presser Bar Spring Screw Stud                          |
| 7309     | 18296 | " Foot Cap                                             |
| 220J     | 18296 | " " " Screw                                            |
| 7310     | 18296 | " " Hinge Connection                                   |
| 7311     | 18296 | " " " " Pin                                            |
| 106D     | 18296 | " " " " Hinge Screw                                    |
| 62527    | 18296 | " " " Pin                                              |
| *20921   | 18296 | " " Plate (left)                                       |

From the library of: Diamond Speed Corp

 1  
2  
3  
4  
5

## PARTS FOR MACHINE No. 410w101

| No.      | Plate | Name                                                                                                                             |
|----------|-------|----------------------------------------------------------------------------------------------------------------------------------|
| 20964    | 18296 | Presser Foot Plate (right)                                                                                                       |
| 176J     | 18298 | " " Screw                                                                                                                        |
| 20923    | 18296 | " " Shank with 7311                                                                                                              |
| 20924    | 18296 | " " Bracket                                                                                                                      |
| 20965    | 18296 | Presser Foot (hinged compensating)<br>complete, Nos. 106D, 220J, 7309, 7310,<br>20921, 20924, 20964, two each 20923<br>and 62527 |
| 271025   | 18294 | Rotary Take-up (large)                                                                                                           |
| 210983   | 18298 | " " " Position Pin                                                                                                               |
| 401D     | 18294 | " " " Screw (2)                                                                                                                  |
| 271032   | 18294 | " " " Thread Guide                                                                                                               |
| 270146   | 18327 | " " (small) with 270147 and<br>350418C                                                                                           |
| 270273   | 18327 | Rotary Take-up (small) Driving Shaft                                                                                             |
| 270032   | 18327 | " " " " "                                                                                                                        |
|          |       | Ball Bearing (2)                                                                                                                 |
| 270069   | 18327 | Rotary Take-up (small) Driving Shaft<br>Connection Belt                                                                          |
| 270072   | 18327 | Rotary Take-up (small) Driving Shaft<br>Pulley with two 200382C                                                                  |
| 200382C  | 18327 | Rotary Take-up (small) Driving Shaft<br>Pulley Set Screw                                                                         |
| 350418C  | 18327 | Rotary Take-up (small) Set Screw                                                                                                 |
| 270147   | 18327 | " " " Thread Cast-off<br>Pin                                                                                                     |
| 270148   | 18294 | Rotary Take-up Guard                                                                                                             |
| 350503H  | 18294 | " " " Screw (3)                                                                                                                  |
| 2102     | 18294 | Tension Disc                                                                                                                     |
| 270277   | 18298 | " Releaser (adjustable)                                                                                                          |
| 200132E  | 18298 | " " Screw                                                                                                                        |
| 32572    | 18294 | " Releasing Disc                                                                                                                 |
| 270278   | 18294 | " " Pin                                                                                                                          |
| 13710    | 18294 | " Spring                                                                                                                         |
| 350457C  | 18294 | " Stud                                                                                                                           |
| 200377C  | 18294 | " " Set Screw                                                                                                                    |
| 1560C    | 18294 | " Thumb Nut                                                                                                                      |
| 270279   | 18294 | Tension complete, Nos. 1560C, 13710,<br>32572, 52082, 270278, 270281, 350457C<br>and two 2102                                    |
| 271017   | 18294 | Thread Guide                                                                                                                     |
| 236245   | 18294 | " " (lower)                                                                                                                      |
| 350503H  | 18294 | " " Screw (2)                                                                                                                    |
| 270280   | 18298 | " Pull-off                                                                                                                       |
| 200196E  | 18298 | " " Set Screw                                                                                                                    |
| 271018   | 18294 | " Retainer                                                                                                                       |
| 200355H  | 18294 | " " Set Screw                                                                                                                    |
| 270150   | 18294 | " Severing Finger                                                                                                                |
| 270151   | 18294 | " " " Guard                                                                                                                      |
| 350486XC | 18294 | " " " " Hinge Screw                                                                                                              |
| 270156   | 18294 | " " " " " "                                                                                                                      |
|          |       | Spring Washer                                                                                                                    |
| 200567H  | 18294 | Thread Severing Finger Screw                                                                                                     |

## PARTS FOR MACHINE No. 410w101

| No.    | Plate | Name                                         |
|--------|-------|----------------------------------------------|
| 52082  | 18294 | Thread Take-up Spring                        |
| 270281 | 18294 | " " " Regulator with<br>200377C              |
| 446C   | 18294 | Thread Take-up Spring Regulator Set<br>Screw |
| 20994  | 18296 | Throat Plate with 20969 and two 337J         |
| 20969  | 18296 | " " Needle Guard                             |
| 337J   | 18296 | " " " " Screw                                |
| 691F   | 18296 | " " " Screw (2)                              |

Genuine "SINGER" Needles should be used  
in "SINGER" Machines.  
These Needles and their Containers  
are marked with the  
Company's Trade Mark "SIMANCO" 1

Needles in Containers marked  
"FOR SINGER MACHINES"  
are NOT "SINGER" made needles. 2





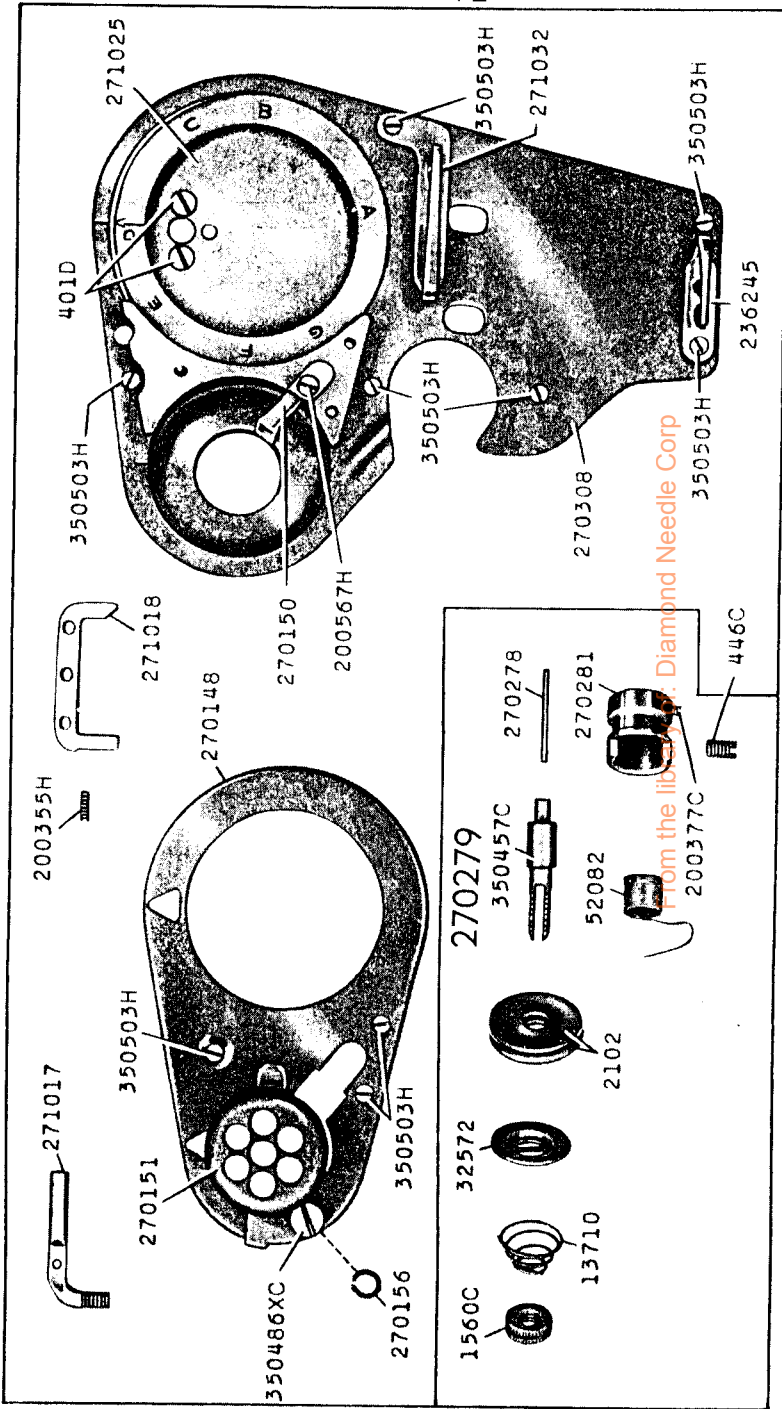
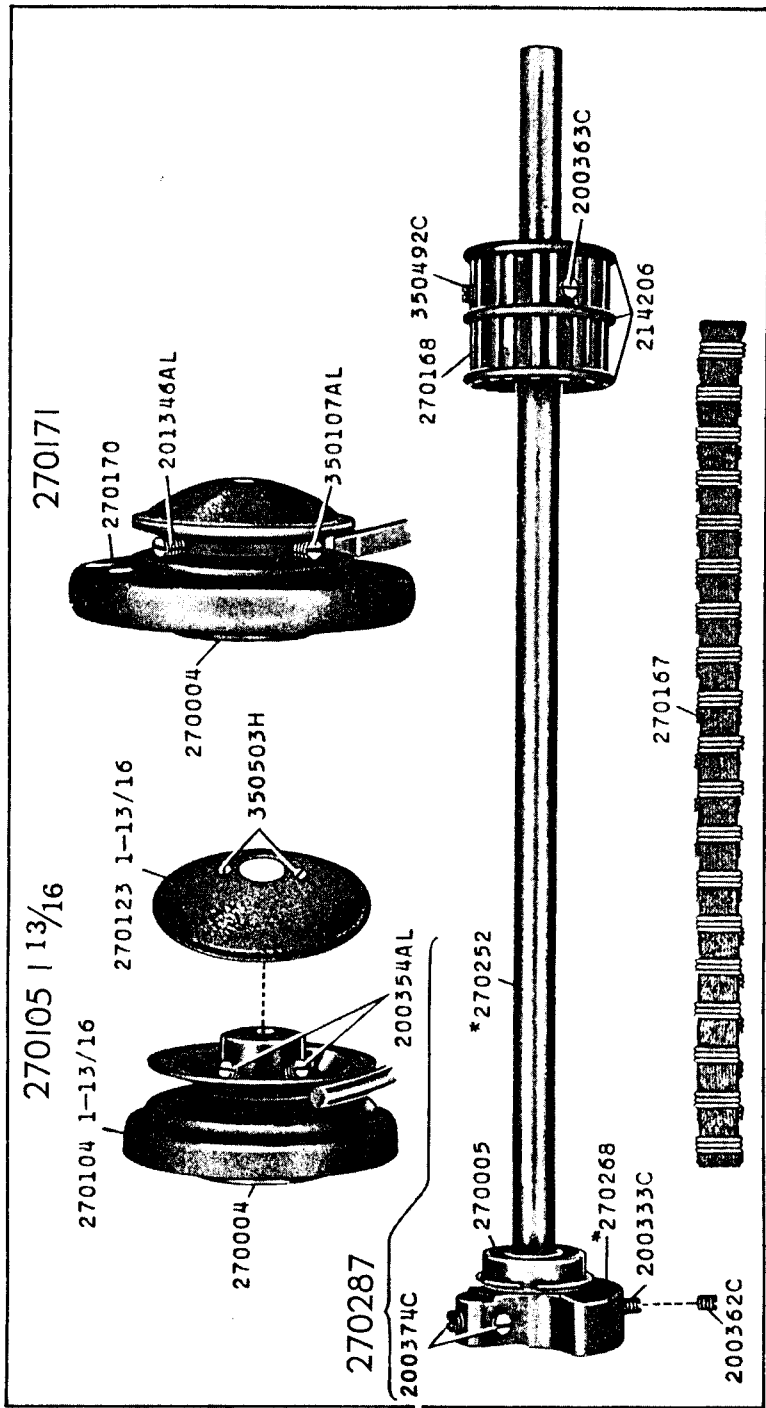

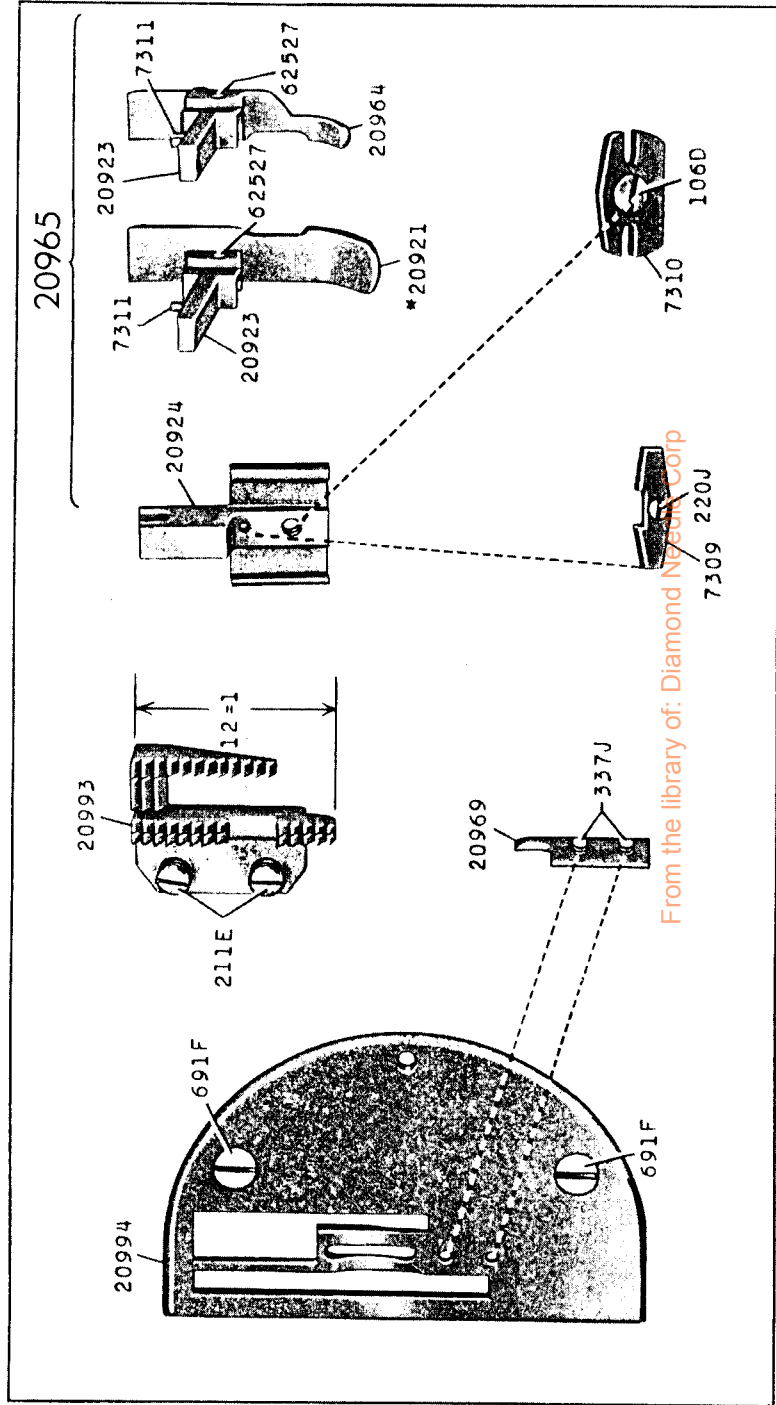
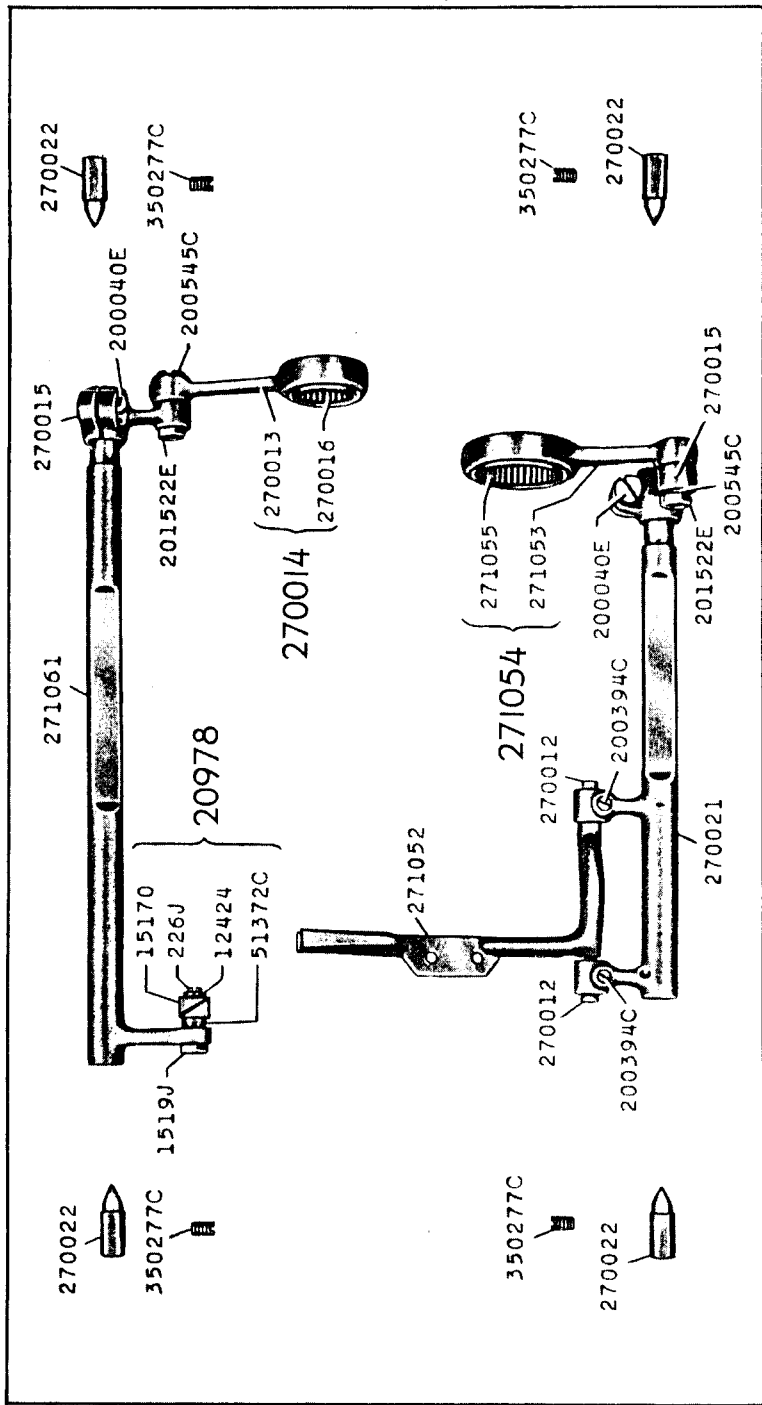



18299 - 1/2

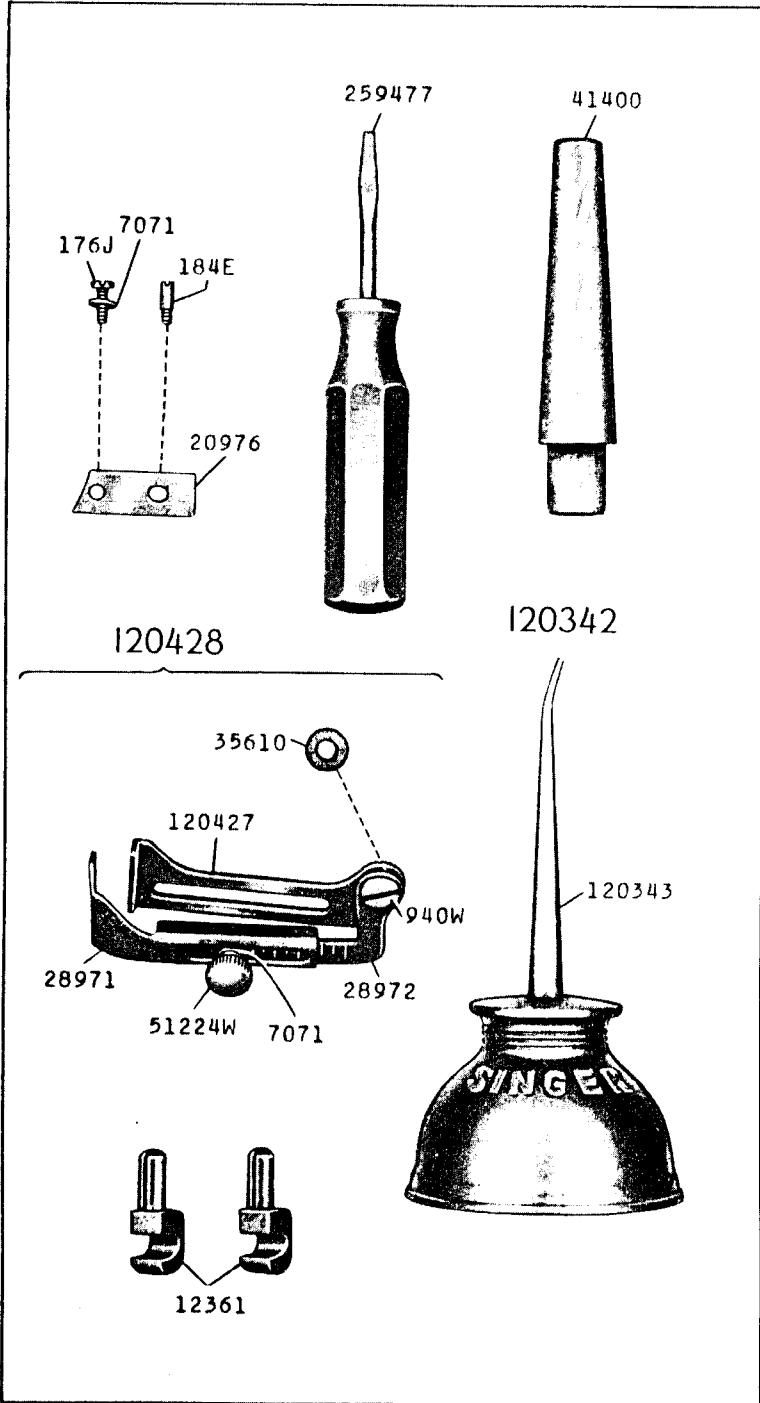

18327 - 3/8

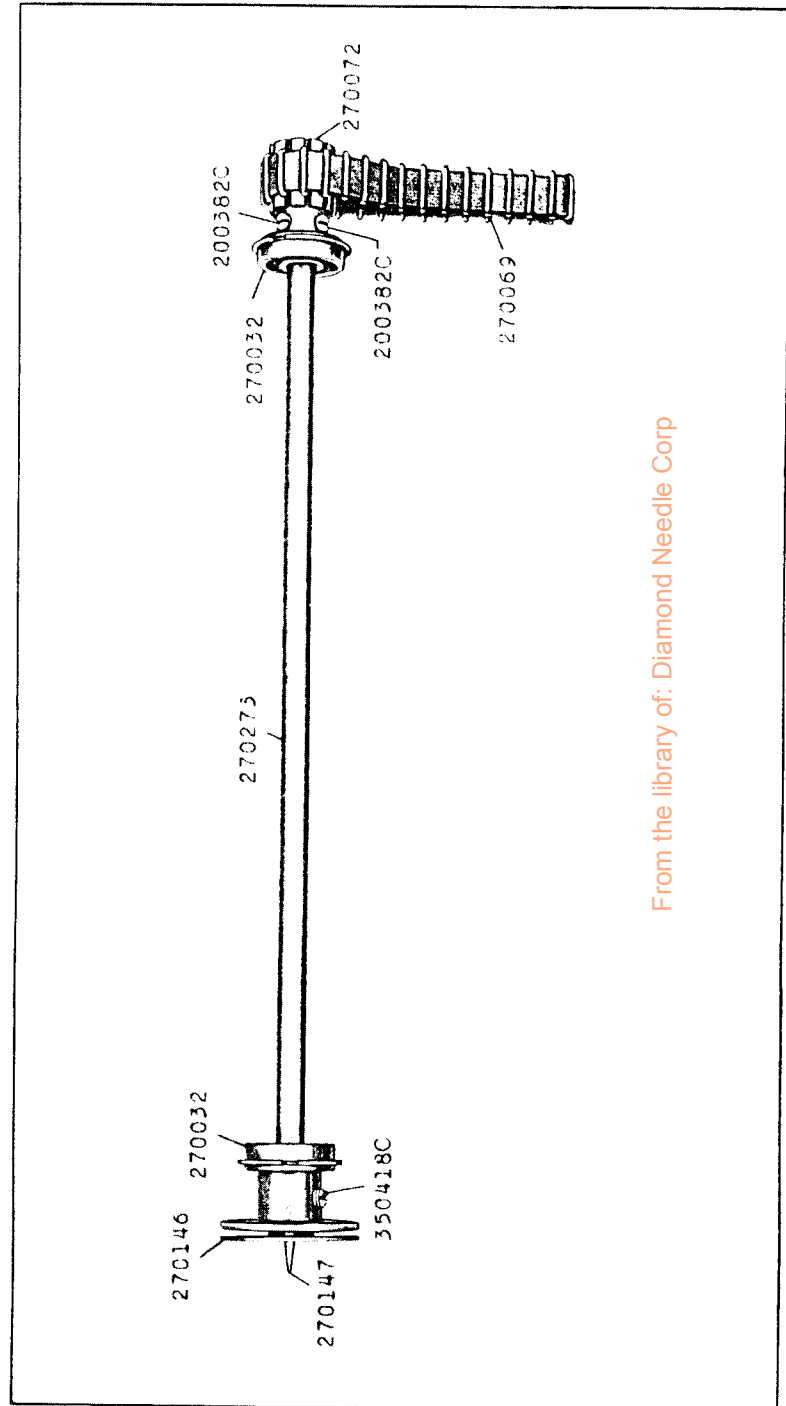

From the library of: Diamond Needle Corp

18333 - 1/4

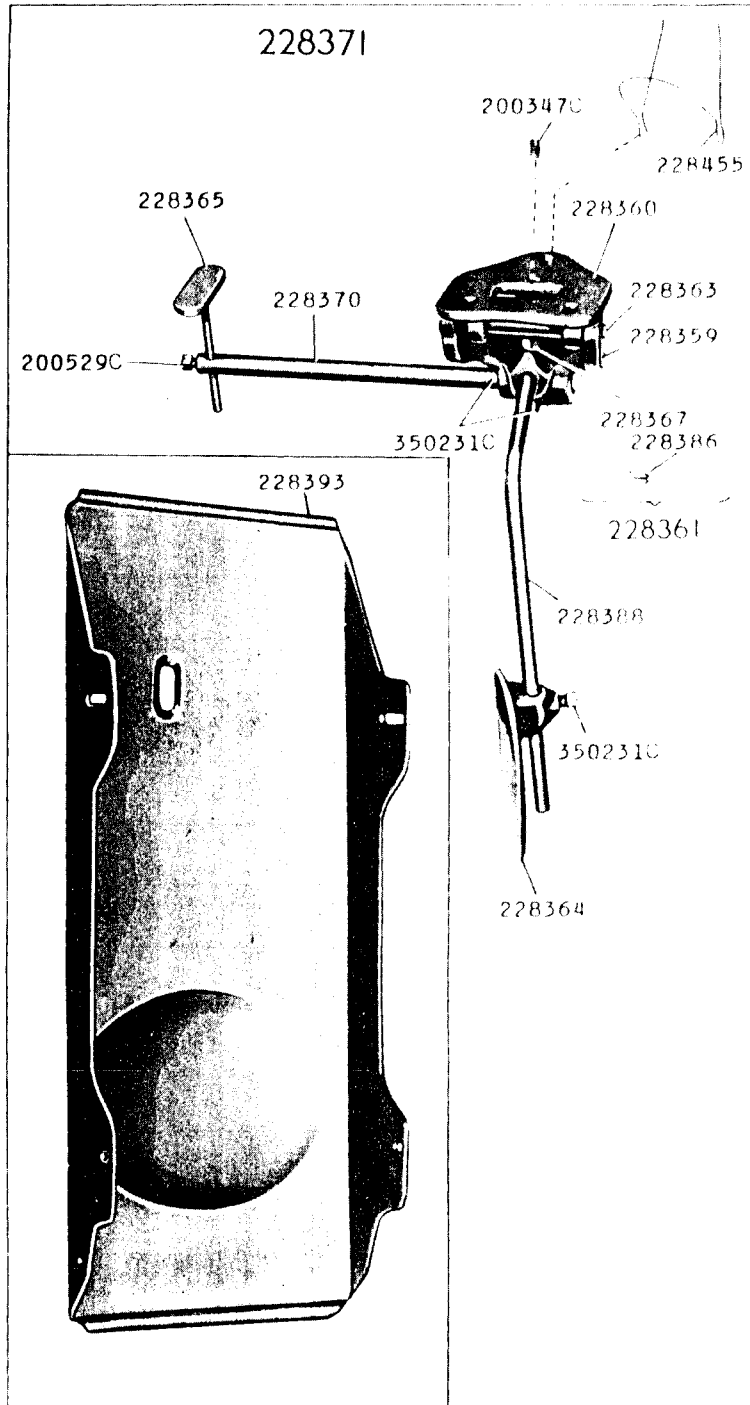

Genuine "SINGER" Needles should be used  
in "SINGER" Machines.  
These Needles and their Containers  
are marked with the  
Company's Trade Mark "SIMANCO"

Needles in Containers marked  
"FOR SINGER MACHINES"  
are NOT "SINGER" made needles.

From the library of: Diamond Needle Corp